

Valve Stacking System L

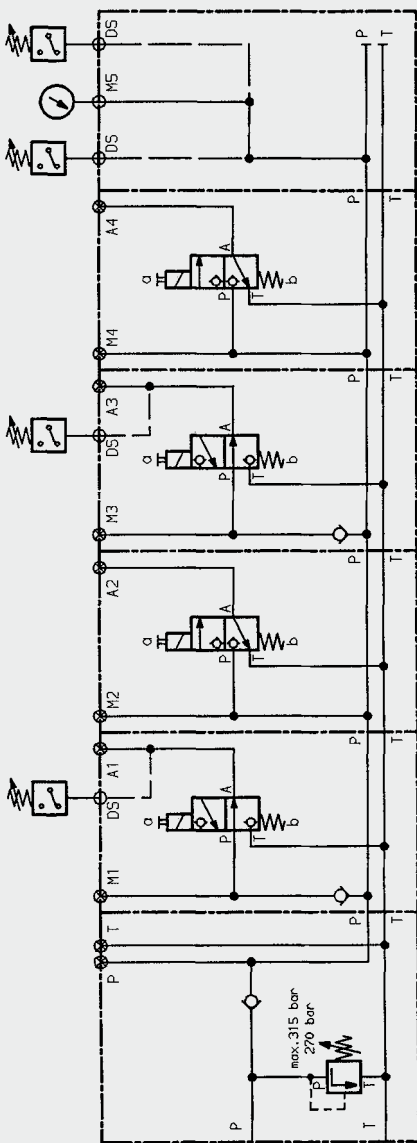

up to 500 bar
up to 12 l/min

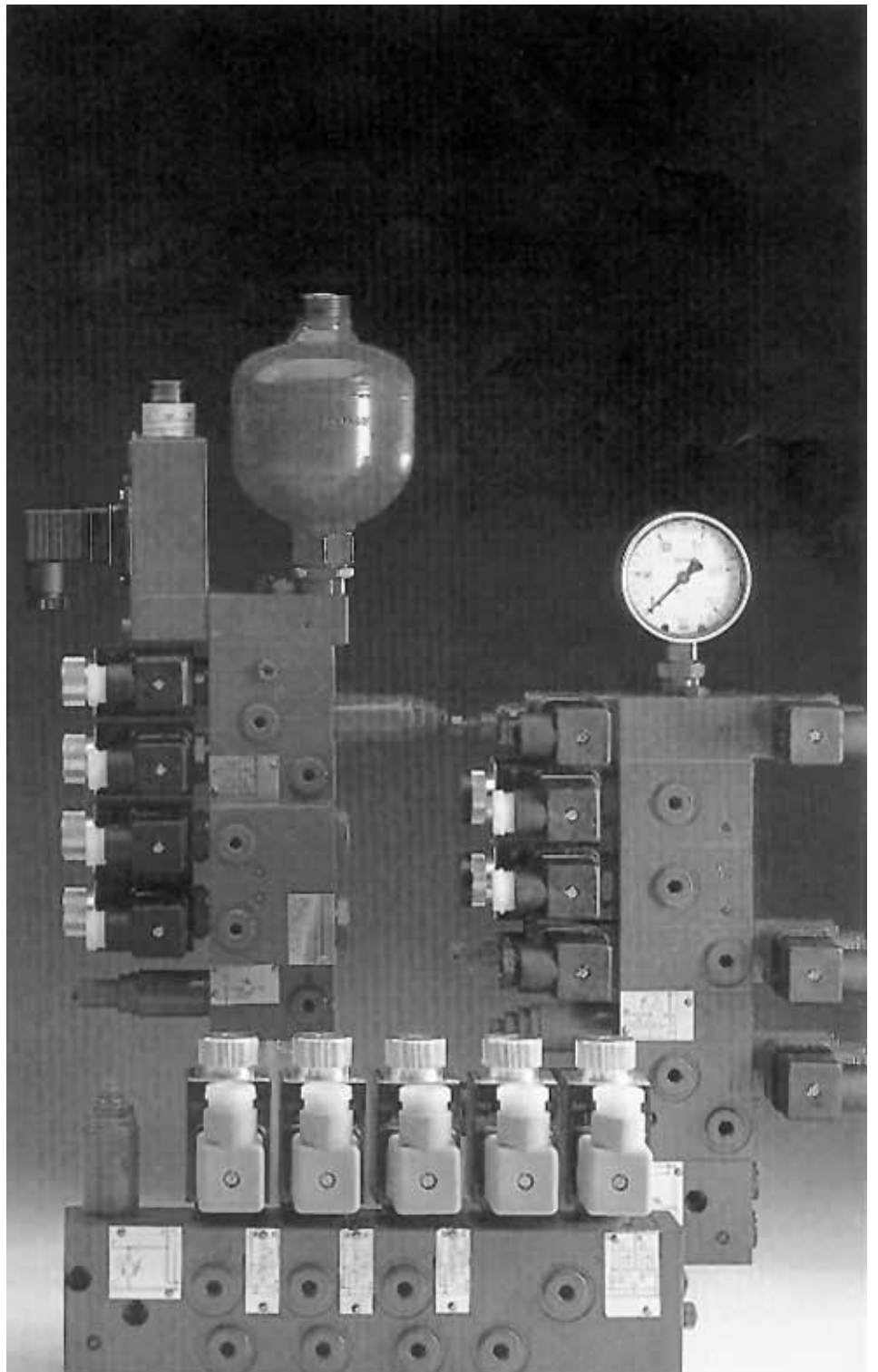

1. DESCRIPTION

1.1 GENERAL

The HYDAC valve stacking system, type L, is a control block composed of individual modules for hydraulic systems in parallel arrangement. This system is designed chiefly for controlling user units with small volumes and pressure/power holding tasks.

Function modules with directional seat valves, pressure and check valves and pressure switches can be combined on the base module in any order, depending on the control task. It is always finished off with an end module with or without an additional function. The stack is held together with two tie-bolts.

Different base modules are suitable for building onto HYDAC HP and CA power units, or onto any hydraulic system by means of an inline base module.

This modular system ensures:

- A high level of flexibility due to variable module arrangement
- Individual solutions to control problems
- Small dimensions and high performance
- No leakage
- Cost-effective control due to series production of modules.

1.2 FUNCTION

With a central pressure and return line, oil can be supplied to or released from several user units simultaneously or independently. It is possible to separate the functions of user units which are in parallel arrangement by using check valves and special modules. Flange-type pressure switches enable simple control of the pump and pressure monitoring, also on the user unit.

Leakage-free directional seat valves provide safe positioning for the user unit and maintain pressures over a longer time without repeated oil feeding.

With the aid of relevant modules, the pressure in the central pressure line can also be shut-off or altered.

1.3 APPLICATIONS

In conjunction with power units, valve stacking systems, type L, are ready-to-install oil supply units.

Particularly compact systems result in conjunction with HYDAC HP and CA power units.

Valve stacking systems are used in the following areas:

- Clamping hydraulics
- Machine tool engineering
- Press construction
- Appliance construction
- Loading and feeding apparatus
- Auxiliary and parallel drives
- Mobile hydraulics etc.

2. SPECIFICATIONS

2.1. GENERAL

2.1.1 Designation

Valve stacking system in parallel arrangement.

2.1.2 Type of construction

Control modules in sandwich stacking construction with valve cartridges and additional devices.

2.1.3 Type of mounting

2 screws M6 for HP and CA mounting.

2 threaded holes M8 in the base block on RL and RLRD and in the end module PF.

It is also possible to insert a mounting sandwich plate in the control (necessary for support when the stack is approx. 500 mm or above in length).

2.1.4 Weight

The total weight of a stack is derived from the sum of the weights of the individual modules (see point 3.2. - 3.4.) and of the valves and units fitted (see point 4).

2.1.5 Ambient temperature

Min. – 20 °C
Max. + 40 °C

2.1.6 Mounting position

When building onto HP and CA, determined by the unit.

As a control strip, optional.

2.1.7 Direction of flow

According to symbol, only permissible in direction of arrow.

2.2 HYDRAULIC DETAILS

2.2.1 Nominal pressure

For building onto inline base block

$p_N = 350$ bar

For building onto CA unit

$p_N = 210$ bar

For building on to HP unit

$p_N = 500$ bar

Exceptions:

modules with 2/2 directional seat valves, symbol Z, Y, V, W

$p_N = 350$ bar

2.2.2 Flow rate

$Q_{max} = 12$ l/min

Pressure-related performance limits of the individual valves and devices must be taken into account. See point 4 for design recommendations.

2.2.3 Operating fluid

Hydraulic oil to DIN 51 524, Part 1 and 2

2.2.4 Temperature of operating fluid

Min. - 20 °C
Max. + 80 °C

2.2.5 Viscosity range

Min. 10 mm²/s
Max. 380 mm²/s

2.2.6 Filtration

Max. permissible contamination level of the operating fluid:

– **For operating pressure up to 350 bar**

ISO 4406, class 21/19/16
(NAS 1638, class 10)

We recommend a filter with a minimum retention rate of $\beta_{20} \geq 100$

– **For operating pressure up to 500 bar**

ISO 4406, class 20/18/15
(NAS 1638, class 9)

We recommend a filter with a minimum retention rate of $\beta_{10} \geq 100$.

The fitting of filters and regular replacement of elements guarantees correct functioning, reduces wear and tear and increases the service life.

2.3 ELECTRICAL DETAILS

2.3.1 Type of actuation

Solenoid-operated by means of pressure-tight, wet-pin single stroke solenoids to VDE 0580.

2.3.2 Type of voltage

Switching solenoids:

DC solenoid
(code G)

For use with AC, the required DC is produced by using a bridge rectifier connector (code W)

Proportional solenoid:

DC solenoid G 24.

2.3.3 Nominal voltage U_N

Standard voltages

Voltage type G: 24 V

Voltage type W: 220 V

Other voltages in the range 6 up to 240 V are also available on request.

2.3.4 Voltage tolerance

+ 10 %
– 5 %

2.3.5 Power consumption

$p_{20} = 26 \text{ W}$

2.3.6 Switch-on time

100 % switch-on time = continuous operation

2.3.7 Safety type

IP 65 to DIN 40050 provided connector is fitted correctly.

2.3.8 Switching frequency

3600 per hour

EXPLODED DIAGRAM OF SYSTEM CONSTRUCTION

End module

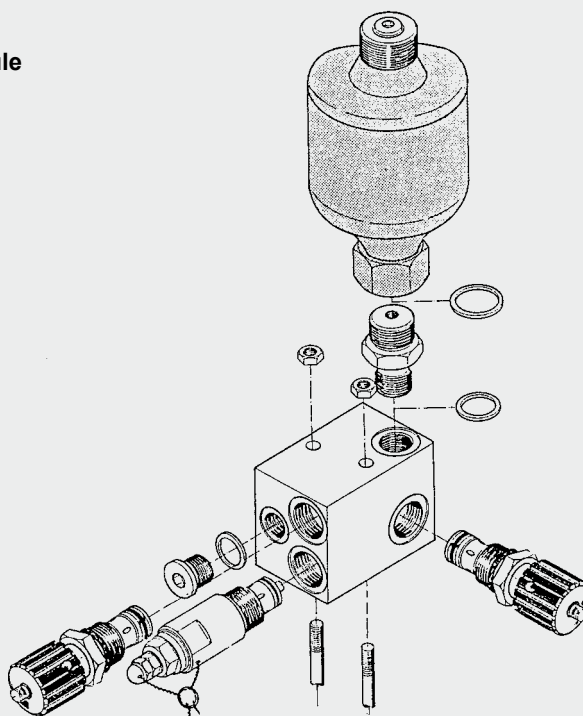

Function modules

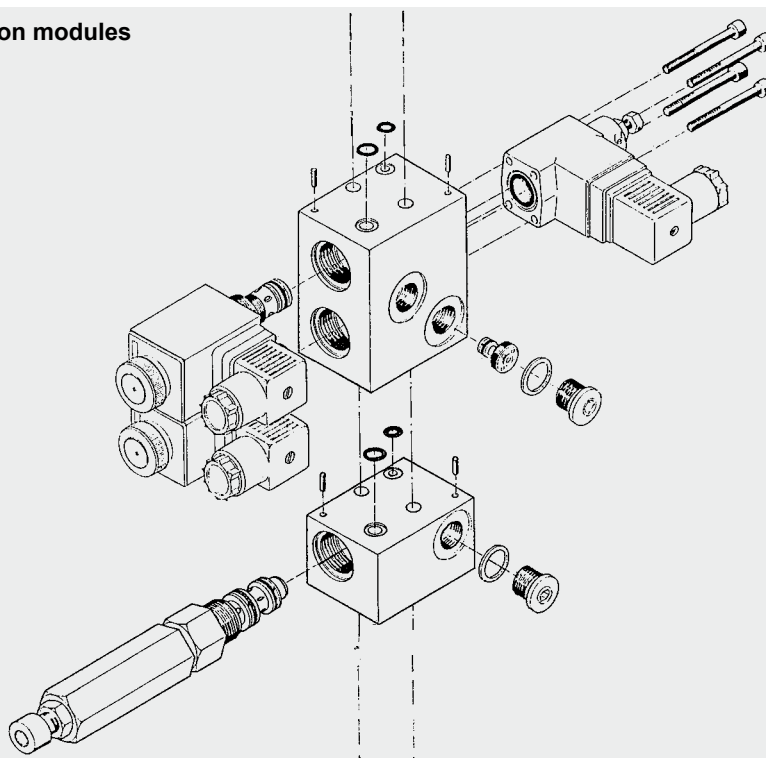

Base module

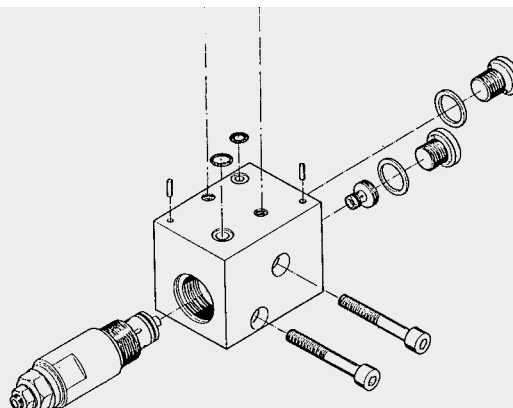

3. SELECTION TABLE, SYMBOL, DIMENSIONS, WEIGHT, TYPE

3.1 MODEL CODE

(also order example)

LR/350M315-270 + DR-7 + C + DR-7 + C + PB-77/63-400 + G24 - Z4 - N

Valve stacking base module
(see point 3.2.)

Function modules
(see point 3.3.)

1st function module

2nd function module

3rd function module

4th function module

... further function modules

End modules (see point 3.4.)

Nominal voltage for actuating solenoids

G 24 ... DC 24 V

W 220 ... AC 220 V - 50/60 Hz

other voltages on request

Electrical connection for actuating solenoids

no details ... DIN 43650 plug without connector

Z4 ... connector to DIN 43650-AF2-PG11

Z5L ... large connector with light

For AC type, connector is automatically supplied with bridge rectifier insert

Manual override on directional seat valves

(see point 4.5.)

no details ... without manual override

N ... pin type operation

NG ... thumb pressure operation
(symbols V, W, Y, C, D only)

Switching circuit corresponding to order example above

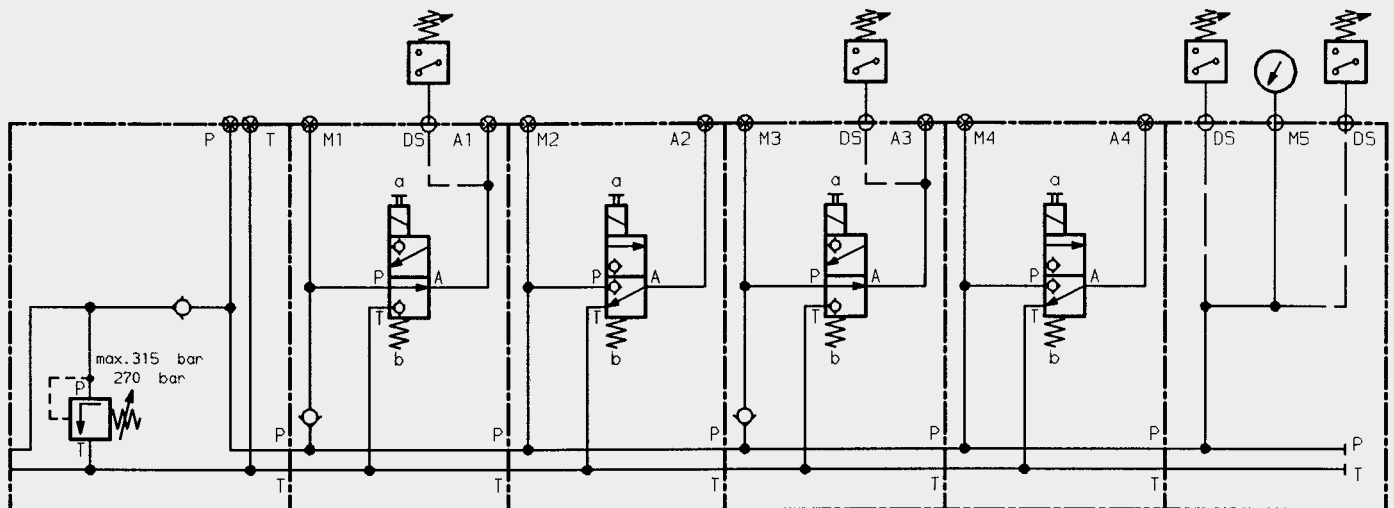

LR/350M315-270

+DR-7

+C

+DR-7

+C

+PB-77/63-400
+G24-Z4-N

3.2 BASE MODULES

Base module RL for inline mounting

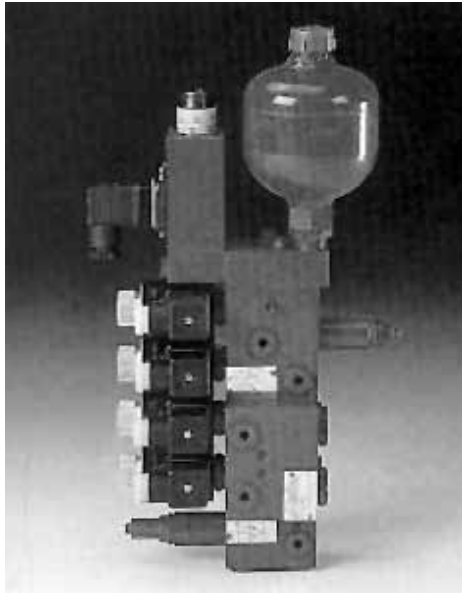

Base module L for flanging to CA power units



Base module L for flanging to HP power units

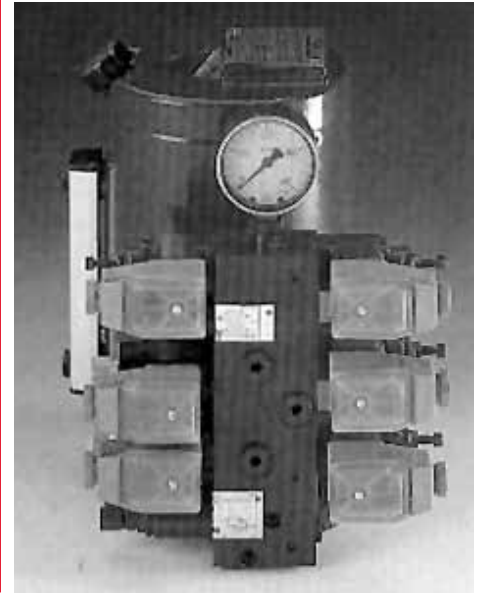

Designation and symbol

3.2.1 Base module for inline mounting

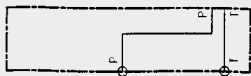

Dimensions

Ports
 P = G 1/4
 T = G 3/8
 Weight 0.57 kg

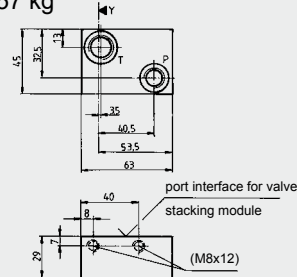

Model code

Base module for inline mounting RL+

3.2.2 Base module for inline mounting

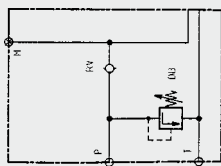

Ports
 M, P = G 1/4
 T = G 3/8
 Weight 0.75 kg

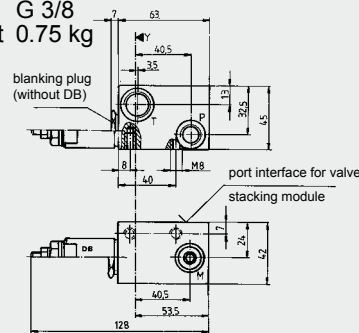

Base module for inline mounting RL R / 350 V+
 Check valve RV
 no details ... without
 R ... with RV
 Pressure relief valve DB
 Pressure range and type of adjustment
 See point 4.2

3.2.3 Base module for flange-mounting

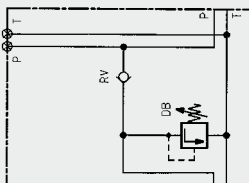

Ports
 P, T = G 1/4
 Weight 0.97 kg

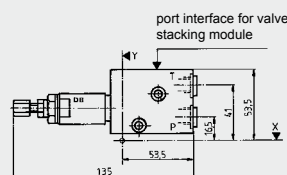

Base module for flange-mounting L R / 350 M 315 +
 Check valve RV
 no details ... without
 R ... with RV
 Pressure relief valve DB
 pressure range and type of adjustment
 See point 4.2
 V-type adjustment not possible on this base module

3.3 FUNCTION MODULES

Ports A, B M ... G 1/4

Designation and symbol

Dimensions

Model code

3.3.1 2/2 Directional seat valve module

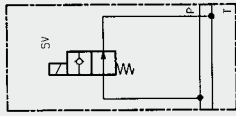

Weight 0.74 kg

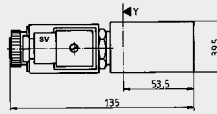

Directional seat valve SV ——— + Y +
possible symbols Z, Y, W, V
see summary point 4.3

3.3.2 2/2 Directional seat valve module

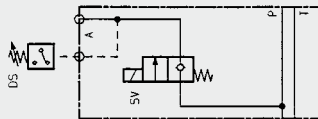

Weight 0.74 kg

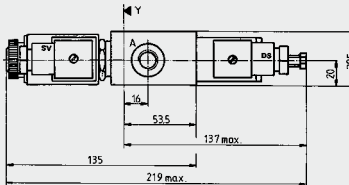

Directional seat valve SV ——— + Z A - 5 +
possible symbols Z, Y, W, V
see summary point 4.3
Module code ———
Pressure switch DS ———
no details ... without
5-8 ... see point 4.4

3.3.3 2/2 Directional seat valve module

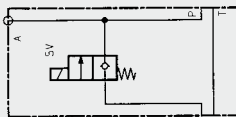

Weight 0.74 kg

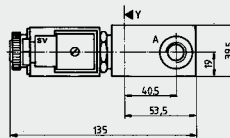

Directional seat valve SV ——— + Z P +
possible symbols Z, Y, W, V
see summary point 4.3
Module code ———

3.3.4 2/2 Directional seat valve module

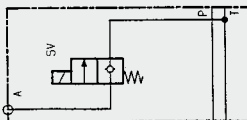

Weight 0.75 kg

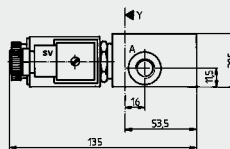

Directional seat valve SV ——— + Z T +
possible symbols Z, Y, W, V
see summary point 4.3
Module code ———

3.3.5 2/2 Directional seat valve module

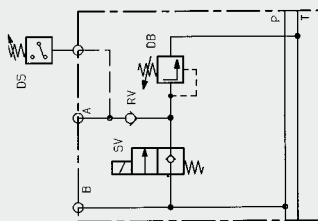

Weight 1.45 kg

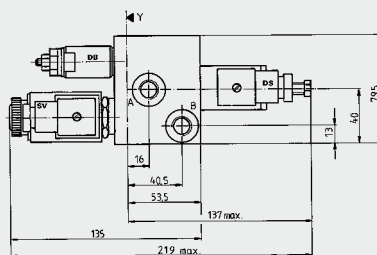

Directional seat valve SV ——— + Z R - 6 / 350 V +
possible symbols Z, Y, W, V
see summary point 4.3
Check valve ———
no details ... without
R ... with RV
Pressure switch DS ———
no details ... without
5 - 8 ... see point 4.4
Pressure relief valve DB ———
pressure range and type of
adjustment
see point 4.2

Designation and symbol

3.3.6 2/2 Directional seat valve combination

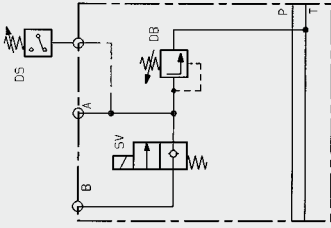

Dimensions

Weight 1.45 kg

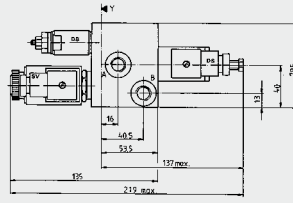

Model code

Directional seat valve SV ———— **+ Z T - 6 / 350 V +**
 possible symbols Z, Y, W, V
 see summary point 4.3
Module code ————
Pressure switch DS ————
 no details ... without
 5 – 8 ... see point 4.4
Pressure relief valve DB ————
pressure range and type of adjustment
 see point 4.2

3.3.7 2/2 Directional seat valve combination

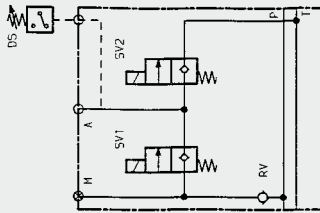

Weight 1.48 kg
 DS – series 5-8

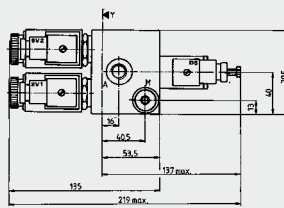

Module code ———— **+ E R Z Z - 3 +**
Check valve ————
 no details ... without
 R ... with RV
Directional seat valve SV1 ————
Directional seat valve SV2 ————
 possible symbols for SV1 and SV2:
 Z, Y, W, V
 see summary point 4.3
Pressure switch DS ————
 no details ... without
 5 – 8 ... see point 4.4

3.3.8 2/2 Directional seat valve combination

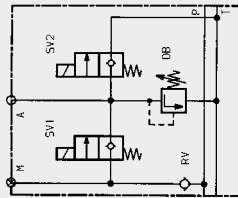

Weight 1.45 kg

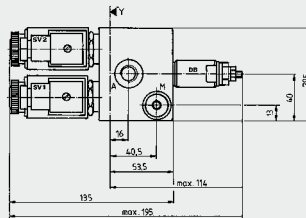

Module code ———— **+ E R Z Z / 350 V +**
Check valve ————
 no details ... without
 R ... with RV
Directional seat valve SV1 ————
Directional seat valve SV2 ————
 possible symbols for SV1 and SV2: Z, Y, W, V
 see summary point 4.3
Pressure relief valve DB ————
pressure range and type of adjustment
 see point 4.2

3.3.9 Pressure relief valve module

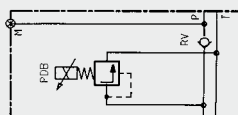

Weight 0.74 kg

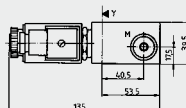

Module code ———— **+ M R P 210 A +**
Check valve ————
 no details ... without
 R ... with RV
Pressure relief valve ————
 P ... proportional pressure relief valve PDB
 D ... pressure relief valve DB 4 (not illustrated)
Pressure range ————
 code P:
 70 (... 70 bar)
 210 (... 210 bar)
 350 (... 350 bar)
 code D: see point 4.2
Code ————
 Control amplifier for code P (PDB)
 A ... Z4, without control amplifier
 B ... plug amplifier
 C ... module can be clipped to DIN rails
 D ... 19" Euro card
 For type of adjustment for code D (DB4), see point 4.2

Designation and symbol

3.3.10 3/2 Directional seat valve module

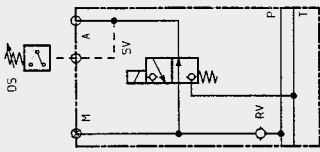

Dimensions

Weight 0.71 kg
DS – series 5 – 8

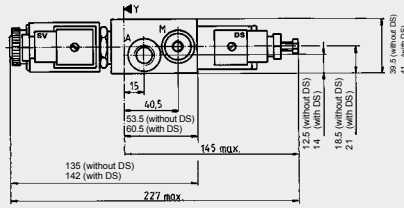

Model code

Directional seat valve SV + D R - 2 +
possible symbols C, D
see summary point 4.3.
Code _____
no details ... without
additional elements
B ... orifice / Ø in mm
R ... check valve RV
Pressure switch DS
no details ... without
5 – 8 ... see point 4.4

3.3.11 3/2 Directional seat valve module

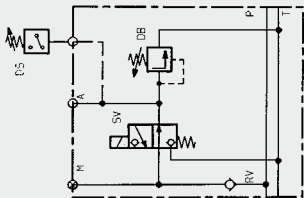

Weight 1.47 kg

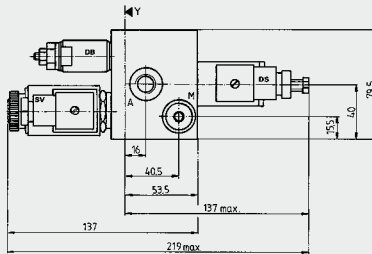

Directional seat valve SV + D R - 5 / 350 V +
possible symbols C, D
see summary point 4.3
Code _____
no details ... without
additional elements
B ... orifice / Ø in mm
R ... check valve RV
Pressure switch DS
no details ... without
5 – 8 ... see point 4.4
Pressure relief valve DB
pressure range and type of adjustment
see point 4.2

3.3.12 4/3 Directional seat valve module

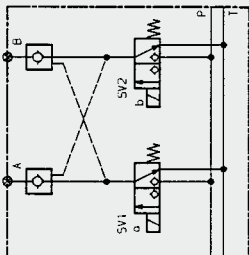

Weight 2.16 kg

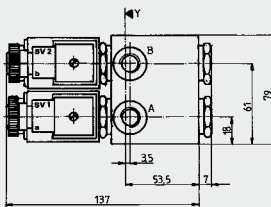

Module code + K +

3.3.13 4/3 Directional seat valve module

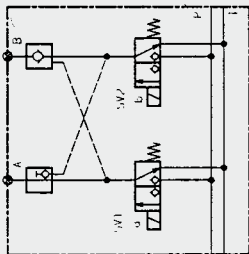

Weight 2.16 kg

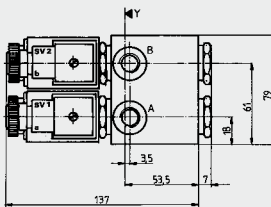

Module code + L +

3.3.14 Check valve module

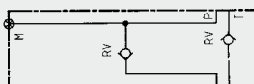

Weight 0.79 kg

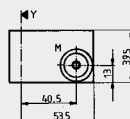

Module code + R PT +

Code _____
Check valve RV
P ... RV in P line
T ... RV in T line
PT ... RV in P and T line
Cracking pressure $p_o = 0.5$ bar

Designation and symbol

3.3.15 Pressure reducing module

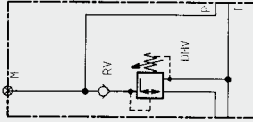

Dimensions

Weight 0.7 kg

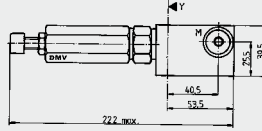

Model code

+ RM 140 V 40 R+

Module code _____

Pressure range pressure reducing valve DMV _____

50 (... 50 bar)

140 (... 140 bar)

Type of adjustment DMV _____

V ... adjustable using tool

H ... hand wheel

A ... hand wheel, lockable, type 2H lock

see point 4.6

Setting pressure DMV _____

no details ... valve not set (spring relaxed)

Check valve RV _____

no details ... without

R ... with RV

3.3.16 Pressure reducing module

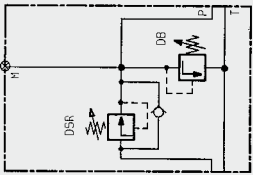

Weight 1.53 kg

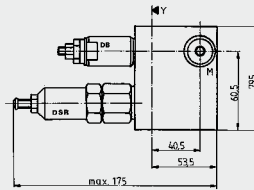

+ H 350 V 290 / 350 V +

Module code _____

Pressure range pressure reducing valve DSR _____

100 (... 100 bar)

250 (... 250 bar)

350 (... 350 bar)

Type of adjustment DSR _____

V ... adjustable using tool

Pre-set closing pressure DB pressure range and type of adjustment _____

see point 4.2

3.3.17 Pressure switch module

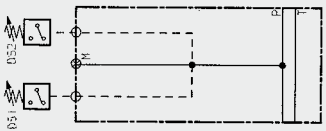

Weight 0.6 kg

DS – series 5 – 8

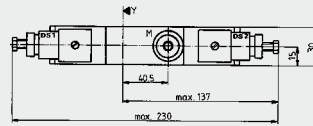

+ G - 3 3 +

Module code _____

Pressure switch DS1 _____

5–8 ... see point 4.4

Pressure switch DS2 _____

1 – 4 ... or

5 – 8 ... see point 4.4

If only one figure is given, DS1 is removed.

Combining series 1 – 4 with 5 – 8 is not possible.

3.3.18 Mounting sandwich plate



Weight 0.23 kg

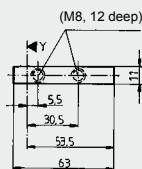

+ BP +

Module code _____

3.4 END MODULES

Designation and symbol

Dimensions

Model code

3.4.1 Standard end module

Weight 0.21 kg

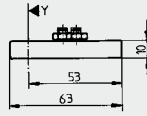

Module code _____ + PA +

3.4.2 End module with mounting thread

Weight 0.20 kg

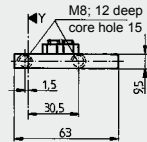
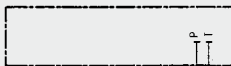

Module code _____ + PF +

3.4.3 End module with pressure gauge and pressure switches

Weight 0.61 kg

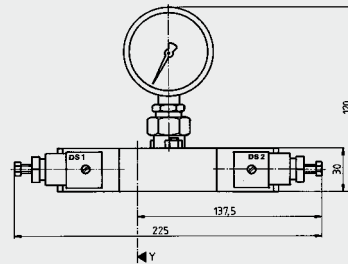
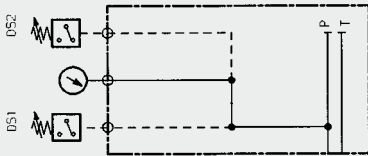

Module code _____ + PB - 5 5 / 63-100

Pressure switch DS1
no details ... without
5 – 8 ... see pt. 4.4

Pressure switch DS2
no details ... without
5 – 8 ... see pt. 4.4

If only one figure is given,
DS2 is removed

Pressure gauge Ø 63 mm
no details ... without

Gauge range:
100 bar
160 bar
250 bar
400 bar
600 bar
1000 bar

Note:
Pressure range max. 2/3 of scale range

Designation and symbol

3.4.4 End module with accumulator and 2 pressure switches

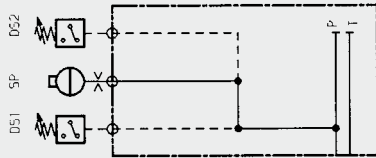

Dimensions

Weight 0.66 kg

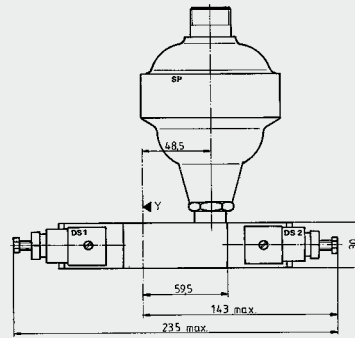

Model code

Code _____ + PC - 55 / _____

Pressure switch DS1
no details ... without
5 – 8 ... see point 4.4

Pressure switch DS2
no details ... without
5 – 8 ... see point 4.4

If only one figure is given,
DS2 is removed

Details for the pressure accumulator SP
Please give full details,
see point 4.1.2

All pressure accumulators
up to Ø 96 mm can be fitted

3.4.5 Accumulator safety end module

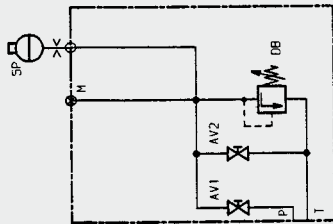

Weight 1.06 kg

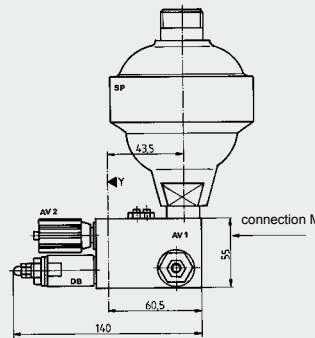

Code _____ + PS 350 P 350 CE / _____

Pressure relief valve DB
Pressure range
see point 4.2

Pressure relief valve DB
Type of adjustment
P ... can be lead-sealed,
on CE version
lead-sealed

Pre-set cracking pressure DB
CE ... with CE approval for DB
no details ... no CE approval for DB

Details for pressure accumulator SP
Please quote in full,
see point 4.1.2

All pressure accumulators
up to Ø 96 mm can be fitted.

4. DESIGN RECOMMENDATIONS

4.1 DOCUMENTATION

4.1.1 Valves and units

- DB – Pressure relief valve DB 4E brochure no. E 5.161
- Pressure relief valves DB 4E pressure-set and lead-sealed brochure no. E 5.163
- PDB – Proportional pressure relief valve, brochure no. E 5.164
- DMV – Pressure reducing valve DMVE-G ½ brochure no. E 5.162
- DV – Flow control valve DV 5E brochure no. 5.113
- RV – Check valve RVE brochure no. E 5.176
- 2SV – 2/2 directional seat valve brochure no. E 5.204
- WSE 3 – 3/2 directional seat valve brochure no. E 5.203
- DS – Pressure switch Series 1–4 Series 5–8
- ERV – Pilot-operated check valve ERVE-R 1/2 brochure no. E 5.172
- DSR – Pressure reducing valve DSR 5E

4.1.2 Hydraulic accumulators

The following hydraulic accumulators can be fitted (when ordering, please state type in full):

Diaphragm accumulators, weld or screw type: SBO Brochure no. E 3.100

Bladder accumulators type: SB Brochure no. E 3.201

4.1.3 Modules

The reference axes X and Y given under the heading **Dimensions** are for calculating the installation dimensions of a complete control. The reference axis X applies only in conjunction with HYDAC HP and CA units.

4.2 ORDER DETAILS FOR PRESSURE RELIEF VALVE DB

350 M 315 - 300

Pressure range

- 100 bar (... 100 bar)
- 200 bar (... 200 bar)
- 350 bar (... 350 bar)
- 630 bar (... 630 bar)

Type of adjustment

- V ... adjustable with tool
- M ... adjustable, advise pressure setting limit
- SM ... scaled knob, advise pressure setting limit (standard)
- P ... can be lead-sealed
- A ... lockable, 2H lock

Max. pressure setting

Must be specified for M and SM
Not required for A, V and P

Pre-set cracking pressure

Optional for M, SM, A, P and V
(no details ... valve not set, spring relaxed)

Type of adjustment:

V



P



M



SM



A

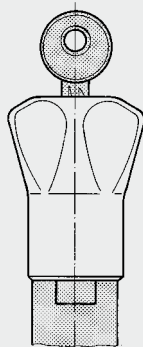

4.3 DIRECTIONAL SEAT VALVES

Symbols

Z

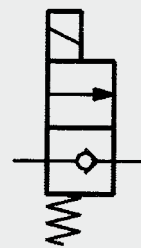

Y

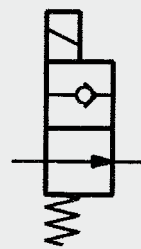

W

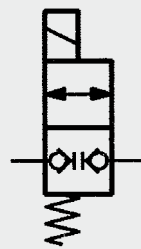

V

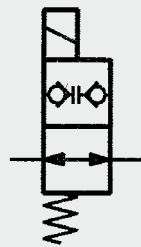

C

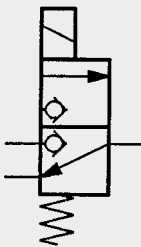

D

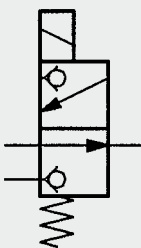

4.4 ORDER DETAILS FOR PRESSURE SWITCH DS

Series 5 – 8

Order code	Pressure range
5	50 bar
6	200 bar
7	350 bar
8	630 bar

- With adjustment screw
- Compact construction

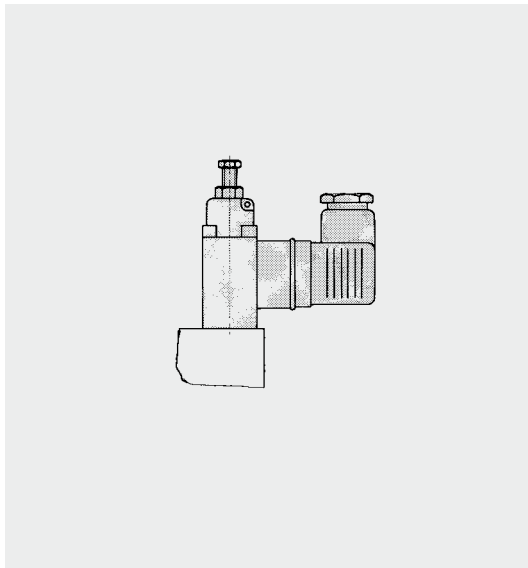

If solenoid valves with Z4 connectors are ordered, pressure switches with Z14 connectors are supplied (standard).

If solenoid valves with Z5L connectors are ordered, pressure switches with Z15L connectors are supplied.

NOTE

The information in this brochure relates to the operating conditions and applications described.

For applications or operating conditions not described, please contact the relevant technical department.

Subject to technical modifications.

4.5 MANUAL OVERRIDE FOR DIRECTIONAL SEAT VALVES

N ... Push-pin type operation

Available for symbols V, W, Y, C, D

Mechanical operation is only possible with a pin.

The opening has a diameter of 5 mm.

The pin is countersunk by 2.5 mm.

The operating stroke is 1.5 mm

The valve is switched as pressure is applied to the actuating mechanism by means of an appropriate pin.

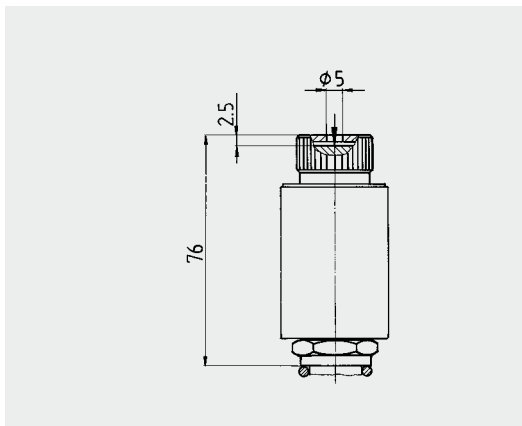

N ... Pull-pin type operation

Available for symbol Z

The valve is switched as the actuating mechanism is pulled out using an appropriate tool.

The operating stroke is 1.5 mm.

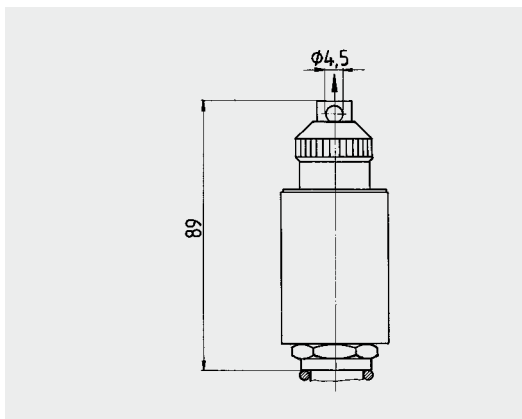

NG ... thumb pressure operation (rubber cap)

Available for symbols V, W, Y, C, D

Manual operation is possible without tool (thumb pressure)

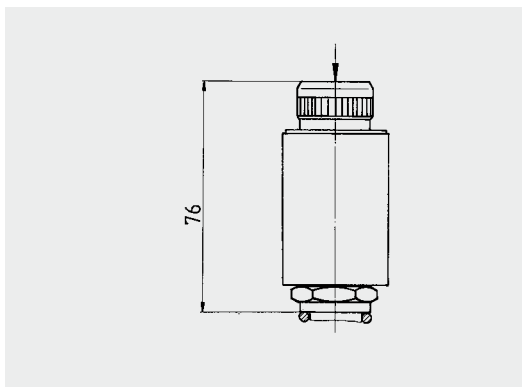

4.6 ORDER DETAILS FOR PRESSURE REDUCING VALVES DMV

Type of adjustment

- V ... adjustable using tool
- H ... hand wheel
- A ... hand wheel, lockable, type 2H lock

V

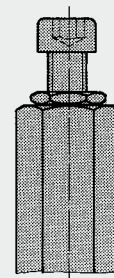

H

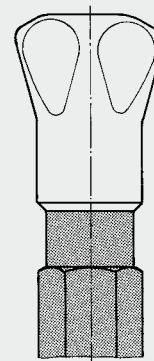

A

