



Electronic Temperature Switch ETS 3200 for Tank Installation

Description:

The ETS 3200 is a compact electronic temperature switch with digital display.

With its integrated temperature probe, the ETS 3200 is particularly suitable for direct tank installation and is available in various lengths.

Different output models with one or two switching outputs, optionally with an additional analogue output signal, offer a variety of application possibilities.

The switching points and the associated hystereses can be adjusted very quickly and easily using the keypad.

For optimum adaptation to the particular application, the instrument has many additional adjustment parameters (e.g. switching delay times, N/C / N/O function, etc.).

Special features:

- 2 switching outputs, up to 1.2 A load per output
- Optional analogue output signal selectable (4 .. 20 mA, 0 .. 10 V)
- 4-digit display
- Optimum alignment - display can be rotated in two planes (axes)
- Switching / switch-back points and many useful additional functions can be set using the keypad.
- Display of temperature and unit of measurement in °C or °F

Technical data:

Input data	
Measuring range	-25 .. 100 °C (-13 ... 212 °F)
Probe lengths	100; 250; 350 mm
Pressure resistance	50 bar
Mechanical connection	G1/2 A DIN 3852
Torque value	45 Nm
Parts in contact with medium	Mech. conn.: Stainless steel Seal: FPM
Output data	
Accuracy (display, analogue output)	≤ ± 1.0 °C (≤ ± 2.0 °F)
Temperature drift (environment)	≤ ± 0.015 % FS / °C max. zero point ≤ ± 0.015 % FS / °C max. range
Analogue output (optional)	
Signal	selectable: 4 .. 20 mA ohmic resist. max. 500 Ω 0 .. 10 V ohmic resistance min. 1 kΩ corresponds in each case to -25 .. +100 °C
Switch outputs	
Type	PNP transistor switching outputs
Switching current	max. 1.2 A per output
Switching cycles	> 100 million
Rise time to DIN EN 60751	t ₅₀ : 8 s t ₉₀ : 15 s
Environmental conditions	
Ambient temperature range	-25 .. +80 °C (-25 ... +60°C acc. to UL spec.)
Storage temperature range	-40 .. +80 °C
Fluid temperature range ¹⁾	-40 .. +100 °C / -25 .. +100 °C
CE mark	EN 61000-6-1 / 2 / 3 / 4
cULus-mark ²⁾	Certificate No. E318391
Vibration resistance to DIN EN 60068-2-6 (0 .. 500 Hz)	≤ 10 g
Shock resistance to DIN EN 60068-2-29 (11 ms)	≤ 50 g
Protection class to IEC 60529	IP 67
Other data	
Supply voltage	9 .. 35 V DC without analogue output 18 .. 35 V DC with analogue output for use acc. to UL spec. - limited energy - according to 9.3 UL 61010; Class 2; UL 1310/1585; LPS UL 60950
Current consumption	max. 2.455 A total max. 35 mA with inactive switching outputs max. 55 mA with inactive switching outputs and analogue output
Residual ripple of supply voltage	≤ 5 %
Display	4-digit, LED, 7 segment, red, height of digits 7 mm
Weight	~ 150 g (probe length 100 mm) ~ 185 g (probe length 250 mm) ~ 210 g (probe length 350 mm)

Note: Reverse polarity protection of the supply voltage, excess voltage, override and short circuit protection are provided.

FS (Full Scale) = relative to complete measuring range

¹⁾ -25 °C with FPM seal, -40 °C on request

²⁾ Environmental conditions according to 1.4.2 UL 61010-1; C22.2 No 61010-1

Setting options:

All the settings available on the ETS 3200 are combined in 2 easy-to-navigate menus. To prevent unauthorised adjustment of the instrument, a programming lock can be set.

Setting ranges of the switching points and switch-back hystereses:

Switching point function

Unit	Switching point	Hysteresis	Increment*
°C	-23.0 .. 100.0	1.0 .. 123.5	0.5
°F	-9 .. 212	2 .. 222	1

Window function

Unit	Lower switch value	Upper switch value	Increment*
°C	-23.0 .. 97.5	-22.0 .. 98.5	0.5
°F	-9 .. 208	-7 .. 209	1

* All ranges given in the table are adjustable by the increments shown.

Additional functions:

- Switching mode of the switching outputs adjustable (switching point function or window function)
- Switching direction of the switching outputs adjustable (N/C or N/O)
- Switch-on and switch-off delay adjustable from 0.00 .. 99.99 seconds
- Choice of display (actual temperature, peak temperature, switching point 1, switching point 2, display off)

Pin connections:

M12x1, 4 pole

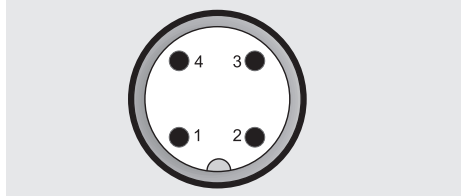

Pin	ETS 3226-2	ETS 3226-3
1	+U _B	+U _B
2	SP 2	Analogue
3	0 V	0 V
4	SP 1	SP 1

M12x1, 5 pole

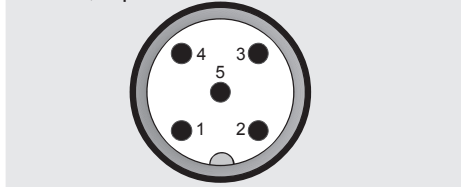

Pin	ETS 3228-5
1	+U _B
2	Analogue
3	0 V
4	SP 1
5	SP 2

Model code:

ETS 3 2 2 X - X - XXX - 000

Mechanical connection

2 = G1/2 A DIN 3852 (male)

Electrical connection

6 = Male M12x1, 4 pole
only possible on output models "2" and "3"

8 = Male M12x1, 5 pole
only possible on output model "5"

Output

2 = 2 switching outputs
only in conjunction with electrical connection type "6"

3 = 1 switching output and 1 analogue output
only in conjunction with electrical connection type "6"

5 = 2 switching outputs and 1 analogue output
only in conjunction with electrical connection type "8"

Probe length in mm

100; 250; 350

Modification number

000 = Standard

Note:

On instruments with a different modification number, please read the label or the technical amendment details supplied with the instrument.

Accessories:

Appropriate accessories, such as electrical connectors, protective sleeves for tank mounting, splash guards, etc. can be found in the Accessories brochure.

Dimensions:

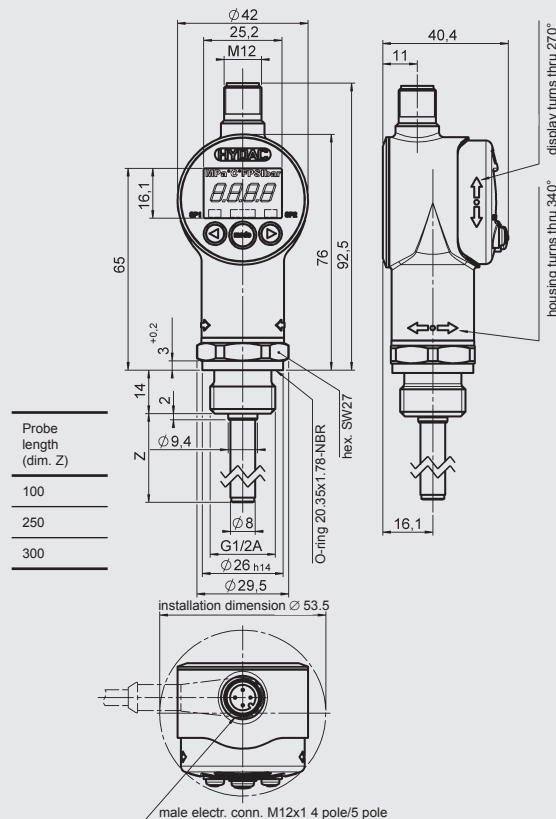

Note:

The information in this brochure relates to the operating conditions and applications described. For applications or operating conditions not described, please contact the relevant technical department. Subject to technical modifications.

HYDAC ELECTRONIC GMBH
Hauptstraße 27, D-66128 Saarbrücken
Telephone +49 (0)6897 509-01
Fax +49 (0)6897 509-1726
E-mail: electronic@hydac.com
Internet: www.hydac.com